

Paradise Industria Aeronautica Ltda.

P-I LSA
AIRCRAFT OPERATING MANUAL



Aircraft Serial #: _____



1. Table of contents

Chapter	Page
Paradise P-I LSA	1
Serial Number	1
1.0 Table of Contents	2-4
2.0 General Information	5-6
Figure 1 - Views and Dimensions	7
3.0 Airplane Systems and description	9
3.1 Engine	9
3.2 Propeller	11
Figure 1 - Warp Drive propeller and protractor	11
3.3 Fuel and Fuel Capacity	12
3.4 Oil	12
3.5 Operating Weight	13
3.6 Structure and System Description	13-14
Figure 2 - Standard Instrument Panel	15
4.0 Operating Limitations	16
4.1 Stall Speed	16
4.2 Flap Extended Range	16
4.3 Maximum Maneuvering Speed	16
4.4 Never Exceed Speed (VNE)	16
4.5 Crosswind Limitation	16
4.6 Service Ceiling	17
4.7 Maximum Load	17
4.8 Prohibited Maneuvers	17
5.0 Weight and Balance	18
5.1 Installed Equipment List	18
5.2 Method to determine BEW	18
5.3 Arm & CG Measurements	18
5.4 CG location and EOW calculation	18
5.5 CG location and TOW calculation	19
Figure 3 - Datum Line, Arm and CG location	20
Table 1 - Weight and balance calculation sheet	21
6.0 Performance	23
6.1 Take off and landing distance	23



6.2	Best rate of climb	23
6.3	Best Angle of Climb	23
6.4	Cruise Speed	23
6.5	RPM	23
6.6	Fuel Consumption	23
7.0	Emergency Procedures	24
7.1	Engine Failure	24
7.1.1	During Take off	24
7.1.2	After Take off	24
7.1.3	During Flight	25
7.2	Emergency Landings	25
7.2.1	Without Engine	25
7.2.2	With Engine Running	26
7.2.3	Landing in water	26
7.3	Engine Fire	27
7.3.1	During start up	27
	a) If engine starts	27
	b) If engine does not start	27
7.3.2	During Take Off	27
	a) On take off run w/enough runway	27
	b) On take off run w/o enough runway	28
8.0	Normal Procedures	29
8.1	Preflight Inspections	29
8.1.1	Approaching Aircraft	29
8.1.2	Inside Cabin	29
8.2	External Inspections	30
8.2.1	Left Landing Gear (Pilot side)	30
8.2.2	Left Wing (Pilot side)	31
8.2.3	Front Fuselage and Engine	32
8.2.4	Right Wing (co-pilot)	33
8.2.5	Right Side Landing Gear	34
8.2.6	Right Side Fuselage	35
8.2.7	Tail Section	36
8.2.8	Left Side Fuselage	37
8.3	Engine Starting	38
8.4	Taxiing	38
8.5	Run Up	38



8.6	Normal Take Off	39
8.7	Best angle of Climb Speed (VX)	39
8.8	Best Rate of Climb Speed (VY)	39
8.9	Cruise	39
8.10	Approach	39
8.11	Landing	39
8.12	Short Field Take Off	40
8.13	Short Field Landing	40
8.14	Go around (balked landing) Procedures	40
9.0	STALLS, SPINS AND OTHER USEFUL INFORMATION	41
10.0	GROUND HANDLING & SERVICING	41
10.1	Fuel, Oil and Coolant	41
10.1.1	Fuel	41
10.1.2	Oil	42
10.1.3	Coolant	42
10.2	Towing	42
10.3	Tie Down	43
10.4	Required Placards & Markings	43
10.4.1	Airspeed Indicator Range Markings	43
10.4.2	Instrument panel operation limitations	43
10.4.3	Passenger Warning	43
10.4.4	"NO INTENTIONAL SPIN"	44
10.5	Miscellaneous Placards & Markings	44-47
11.0	REVISION LIST	49
12.0	CONTACT INFORMATION	51
13.0	APPENDIX A - List of installed equipment	52-53
14.0	APPENDIX B - ROTAX engine Operators Manual	55



Paradise Industria Aeronautica Ltda, has prepared this Pilot Operating Manual in accordance with FAR 21.190, with its content and format defined by ASTM F2245 and supplemented as needed.

This manual has been prepared to inform the owner/pilot of systems and features incorporated in the Paradise P-I LSA aircraft. The enclosed operating procedures and performance data are provided so that maximum utilization can be obtained with the utmost safety, economy and serviceability.

This manual does NOT replace the FAA approved placards and operating limits in a specific aircraft. If a difference exists between this manual and the FAA approved placards / operating limitations, the FAA approved placards and operating limitations shall be the authority.

It should be kept in the aircraft at all times, and it is the pilot's responsibility to assure that the Pilot Operating Handbook - POH is complete and updated with all supplements and revisions. Being a specification manual, it does not replace competent and basic flight training by an appropriately rated instructor, the knowledge of the aerodynamic performance, or the air traffic control rules. It should not be used as guide to basic flight training, it may however be used as complementing reference literature to the training program.

This aircraft was built to conform to the U.S. Light Sport Pilot rules and is intended for Day and Night/VFR use.

The P-I is equipped with non certified engine and configured to meet ASTM standard F 2339.



Manufacturer

Paradise Industria Aeronautica Ltda.
Aeroporto Joao Durval Carneiro
Av. Antonio Sergio Carneiro, s/n
Estr. Do Aeroporto
Feira de Santana, Bahia, Brazil - 44069-010

2. GENERAL DESCRIPTION

The P-1 is a two places, side by side, high wing tractor monoplane. Basic fuselage construction is welded 4130 steel tubing, covered with riveted aluminum sheet. The wings are composed of 5052 H36 grade aluminum spars and ribs and with riveted aluminum sheet. Power is provided by a 100 hp engine, mounted on vibration dampening rubber bushings, and a ground adjustable pitch, three bladed propeller. Good visibility is attained through the use of a one piece windshield, large doors, rear and quarter windows. Basically the P-1 is a conventional three control aircraft. The wheel type dual control system provides smooth and non-fatiguing control. Large aluminum toe brake pedals are provided on the pilot's and passenger side. A trim tab on the stabilator and rudder compensates for load differences and provides for hands-off flight. The stabilator trim tab control is located on the floor between the two occupants, and the rudder adjustment knob on the passenger side of the console. Engine controls are readily accessible from either seat. Concealment of cabin control cables and rods, provide a greater level of comfort. A large baggage compartment is located behind the seat to accommodate luggage and other items. Map compartments are provided at both doors inside panels and behind the seats.

A solid spar aluminum main gear is incorporated into the P-1. This time-tested method of landing gear construction ensures sturdy yet smooth handling on rough fields. Ease in ground handling is assured with steer-able nose wheel and positive-acting mechanical brakes. **NOTE: Do not push or pull aircraft by the propeller, always use the tow-bar to move/steer aircraft.** Tie-down rings are incorporated at the strut wing attachment point and at the underside of the tail section, and should be used for securing the aircraft when parking outside a hangar.

Figure 1 - Views and Dimensions

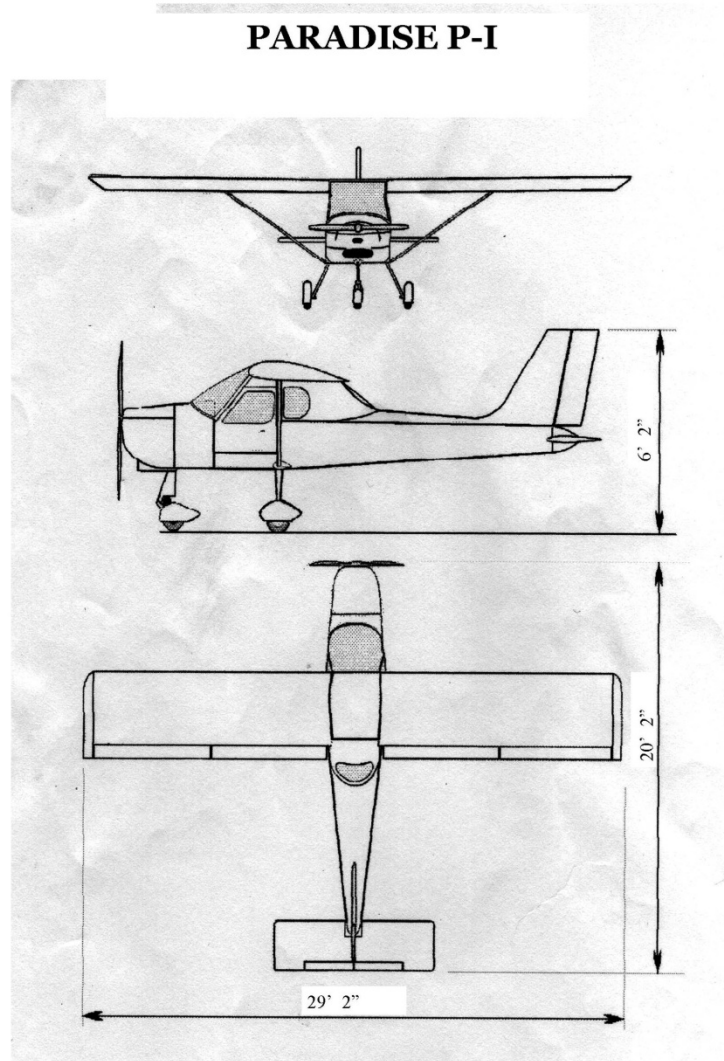



Page intentionally left blank.



3.0 - Airplane and Systems Description

3.1 - Engine

Engine: Rotax 912 ULS 2 - horizontally opposed four cylinder, aspirated four stroke engine. Air cooled cylinders and liquid cooled heads. It incorporates a gear reduction box with 2.43 to 1 ratio.

Cylinder Bore	3.31 in.
Stroke	2.4 in.
Displacement	82.6 cu. In.

Limitations:

Performance (sea level, ISA):	100 hp @ 5800 rpm (5 min.) 95 hp @ 5500 rpm continuous.
Idle speed:	1400 rpm.
Recommended Cruise RPM	5500
Oil type	"See accompanying Rotax manual".
Oil pressure	29/73 (Normal range). 102 psi max. during cold start. 12 psi allowable below 3500 rpm.
Oil Capacity	3.5 qt
Max Oil Temp	266° F (130° C).
Min Oil Temp	120° F (50° C)
Normal Operating Range	190° F - 230° F (90° - 110° C)
Max cylinder head temperature	284° F (135° C).

See Rotax 912 ULS 2 engine Operator's Manual for complete description.

Note: Each aircraft is delivered with the engine manufacturer's handbook. The owner/pilot should read it thoroughly, familiarize himself with the operating procedures and maintenance schedules provided to ensure a **safe operation** and a long life to the engine.



Page intentionally left blank.

3.2 - PROPELLER

The standard propeller is the Warp Drive ground adjustable, nickel edge protected three bladed 68 inches composite propeller. It is factory adjusted for best performance. Any modifications to this adjustment should follow procedures specified by the propeller manufacturer and engine RPM limitations.

Figure 2 - Warp Drive Propeller pitch adjustment with protractor.



3.3 - FUEL and FUEL CAPACITY

The P-I has two wing tanks (one in each wing) with vented caps on the upper side of the wings. Fuel is gravity fed and passes thru a sump system equipped with a quick drain located under the engine cowling. Each fuel tank is equipped with a quick drain located underneath the wings.

Fuel system

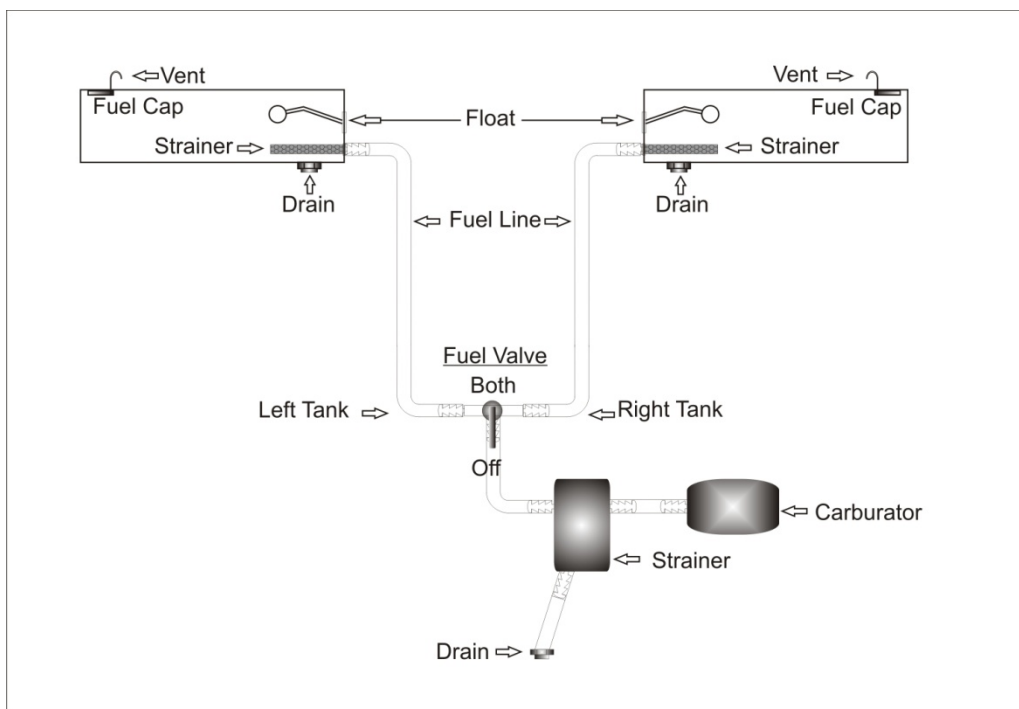

Fuel Type - min. Mon - 85, Ron 95, Min. AKI 91 - Leaded or unleaded or AVGAS 100 LL

<i>Tank capacity (gal)</i>	<i>Total each</i>	<i>Useful each</i>	<i>Total useful</i>
Standard tank	13 gal	12.5 gal	25 gal
Long range tank	19 gal	18 gal	36 gal

For complete fuel specification see the Rotax 912 ULS2 operator's manual.

3.4 - Oil

Oil capacity: 3.5 liq. qt.,

Oil consumption: max 0,13 liq. Pt/h (0,06 l/h).

Oil viscosity: Use of multi viscosity oils is recommended.



Note: According to the manufacturer, Multi-viscosity grade oils are less sensitive to temperature variations than single grade oils. They are suitable for use throughout the seasons, ensure rapid lubrication of all engine components at cold start and get less fluid at higher temperatures.

If engine is run primarily on AVGAS, more frequent oil changes will be required due to lead build-up.

Table of lubricants: See Rotax Engine Service Manual. - Annex 3.

Only Name-Brand, semi-synthetic or full synthetic, 4-stroke motorcycle oil should be used. This engine is equipped with a friction clutch to guard against sudden prop stoppage and for this reason, oils with friction modifiers or additives that favor clutch slippage should not be used.

For complete oil specification see the Rotax 912 ULS2 operator's manual.

3.5 - Operating weights and loading

Maximum take off weight:	1,320 lbs.	(600 kg.)
Typical empty weight:	814 lbs.	(370 kg.)
Typical useful load:	506 lbs.	(230 kg.)
Maximum baggage:	77 lbs.	(35 kg.)

3.6 Structure and Systems Description.

Fuselage: The fuselage of the Paradise P-I is made from welded steel tubing frame covered in aviation grade aluminum sheet.

Wings: The wings are constructed using aviation grade spars and ribs, covered with riveted aviation grade aluminum sheet. The wings are attached to 4 points in the upper part of the cabin and incorporate an aluminum strut.

Wingtips: Wing tips are upwards to help aircraft stabilization, control and reduce stall speed.

Fuel system: Full capacity is 26 gal total/25 gal usable on standard tank and 36 gal total/33 gal usable on long range tanks. Fuel is gravity fed from two wing tanks by means of two independent lines, controlled by 1 valve in the aircraft control panel. Both lines converge to the fuel strainer located in the engine compartment and from there flow to the carburetors.

Electric System: Rotax engines are equipped with a "lightning coil" type alternator and a rectifier-regulator that converts and regulates the output of the alternator to 13.5 - 14.2V nominal (approx. 18A). The system uses a dual CDI ignition system and a sealed type battery.



Landing gear: The landing gear is of the tricycle type. The main gears are heavy duty highly polished aluminum and the nose gear is steel tubing with rubber cushion. The nose gear is directly connected to the pedals providing steering from either pilot or passenger seat.

Brakes: Heavy duty main wheel brakes hydraulic system, actuated from independent pedals on either pilot or passenger seats.

Control surfaces: All control surfaces on the Paradise P-I are made from aviation grade aluminum spars and ribs, and covered with riveted aluminum sheet.

Rudder: The foot pedals operate the conventional aerodynamically balanced rudder by means of control cable.

Stabilator: The Paradise P-I uses an all moving stabilator with counter weight and trim tab. It is actuated by means of push pull rod connected to the yoke column.

Ailerons: The plain type ailerons extend for 50% of the wing length and are controlled by use of control cables connected to the yoke.

Flaps: The fowler with slot type flaps are actuated by means of a mechanical lever located between the pilot and passenger seats. It allows 5 settings: 0° (neutral) , position 1 = 7°, position 2 = 16°, position 3 = 26° and position 4 = 36°. The flap is locked in the selected position by means of a push button at the end of the moving lever.

Pitch trim: The stabilator compensator (trim) is actuated by means of a handle located in the lower console between the seats. It is connected to the tab mechanism by means of control cables.

Rudder trim: The rudder trim is adjusted by means of a control wheel located in the console.

Throttle: RPM control is adjusted by means of the Throttle lever, located on top of the console, between the pilot and passenger seats. Forward movement will increase RPM and it can be reduced by pulling the lever in the opposite direction.

Throttle adjust: The sensibility of the throttle mechanism, can be varied by means of a friction wheel, located at the right (passenger side) of the console. Rotate it CW to increase the lever friction, and CCW to decrease it.

Figure 3 - LSA Standard Instrument Panel and controls.



Paradise P - I LSA

Standard Instrument Panel

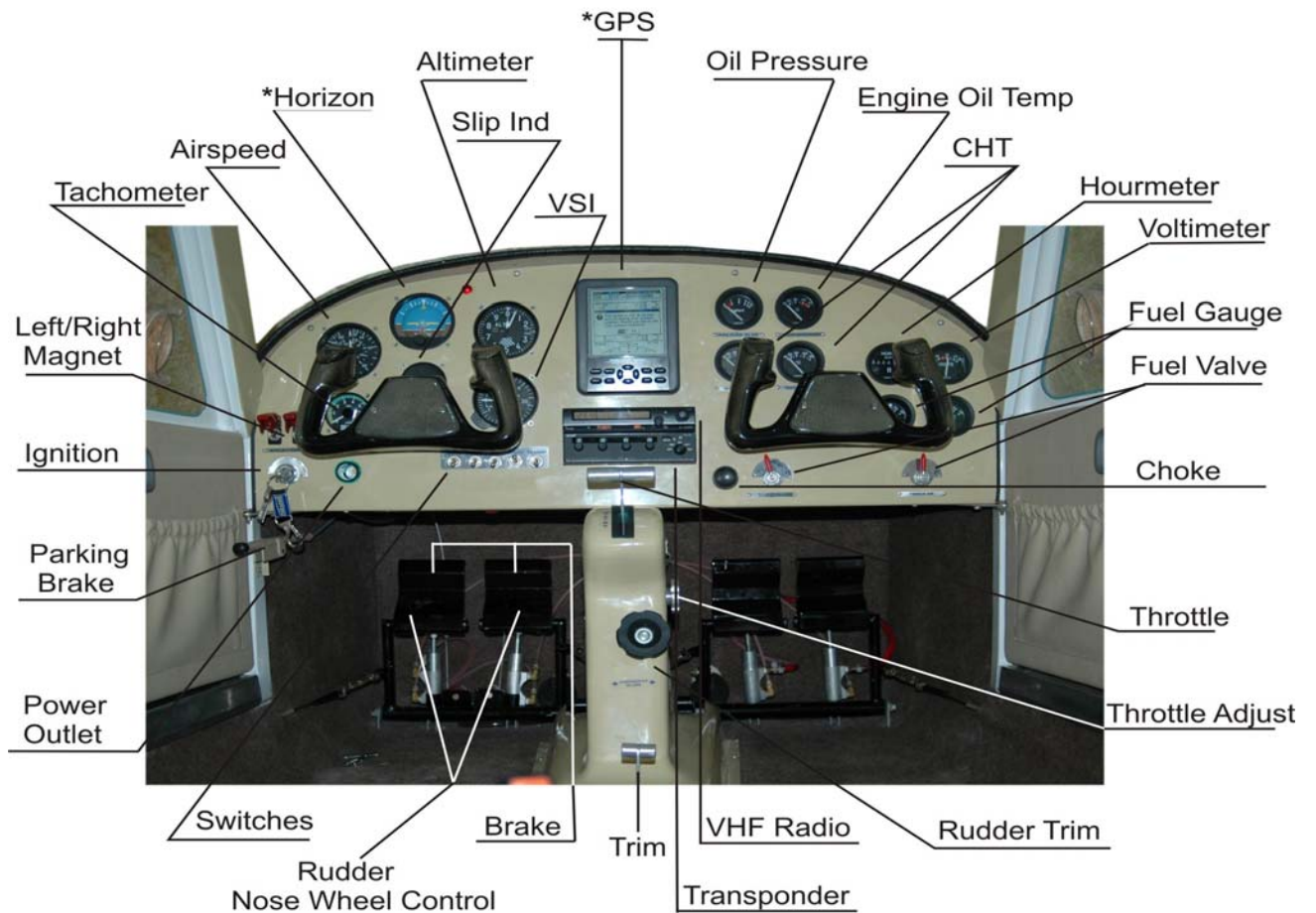

* Optional



The Paradise P-1 SLSA comes in two versions. The Standard aircraft and the Special version with hand controls.

The panel can be designed to fit the owners need, and below are some options.

1. The P-1 SLSA Standard - day VFR basic panel.

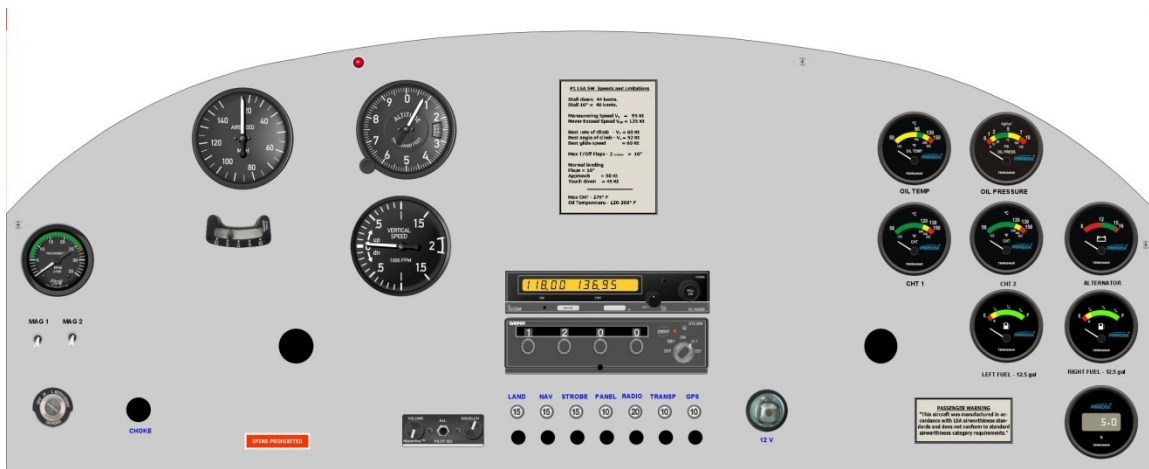

2. P1 SLSA Standard - Night VFR glass panel.



3. P-1 SLSA Special - Night VFR panel.





4.0 - Operating limitations (all speed shown are CAS).

4.1 - Stall speed at MTOW (V_s , V_{s1} and V_{so}).

V_s : Stalling speed or the minimum steady flight at which the airplane is controllable.

V_{s1} : Stalling speed or the minimum steady flight speed obtained in a specific configuration.

V_{so} : Stalling speed or the minimum steady flight speed at landing configuration.

V_s	Flaps 0°	44 Kt	81 Km/h
V_{s3}	Flaps 16°	40 Kt	74 Km/h
V_{so}	Flaps 36°	38 Kt	70 Km/h

4.2 - Flap extended speed range (V_{so} to V_{fe}):

The white arc on the airspeed indicator is from V_{so} to V_{fe} Flaps 16°.

V_{fe} = Maximum flap extended speed.

V_{fe} (CAS)

V_{s1}	Flaps 7°	70 Kt	129 Km/h
V_{s2}	Flaps 16°	70 Kt	129 Km/h
V_{s3}	Flaps 26°	67 Kt	124 Km/h
V_{so}	Flaps 36°	67 Kt	124 Km/h

4.3 - Maximum maneuvering speed (V_A)

V_A : Design maneuvering speed. (Above this speed, full or abrupt deflection of control surfaces may cause structural failure).

V_A : (CAS) 96 Kt 178 Km/h

4.4 - Never exceed speed (V_{NE}):

V_{NE} : (CAS) 121 Kt 224 Km/h

4.5 - Crosswind and wind limitations:

P-I LSA is limited to operation with maximum crosswind of 15 Kt (CAS).

Note: Due to its light weight and low speed, LSA aircraft should not be operated with surface winds in excess of 25 Kt (46 km/h).



4.6 - Servicing ceiling

The service ceiling is the maximum altitude at which a climb rate of 100 ft/min. can be achieved and the ceiling for the P-I LSA is 12,000 ft. (3,640 m).

4.7 - Maneuver load factors

	Positive	Negative
Work load with V_a :	+ 4,0 G	-2,0 G
Work load with V_{ne}	+ 4,0 G	-2,0 G
Work load with flaps	+ 2,0 G	0 G

4.8 - Prohibited maneuvers

Flight into known icing conditions, flight under IFR, aerobatics, including intentional spins are prohibited.

5.0 - Weight and Balance

5.1 - Installed equipment list

See appendix A.

5.2 - Method to determine the Basic Empty Weight:

- Remove all loose objects from the aircraft's interior. (charts, shocks, covers)
- Tire pressure should be at the recommended level.
- Drain all fuel thru the wing and engine sump drains.
- Check to assure engine oil level is at the manufacturers recommended level.
- Flaps should be at NEUTRAL - 0° position.
- Place all controls in neutral.
- Place scales under the wheels.
- Using lower portion of the door frame (pilot or passenger side) , level aircraft. If only one scale is available, make separate measurements at each gear and deduct the weight of any leveling blocks used.

5.3 - Measurements.

If you must make L1 and L2 measurements, proceed as follows:

1. Level aircraft.
2. Measure the distance from the nose wheel axle to a line connecting the two main wheels (L1 and L2).
3. Place a plumb bob at the wing's leading edge close to the wing's root.
4. Measure the distance between the plumb bob and the nose wheel axle (L1).
5. Measure the distance from the plumb bob to the line that connects the two main wheels (L2).
6. Add these two measurements and compare to the measurement in step 1.
7. If it is different, repeat the measurement and use average values.

5.4 - CG location and EOW Weight calculation.

To assist you with this calculation, we recommend the use of the first half of the table 1.1.

1. Multiply each one of the measured weights (nose wheel, left and right main gear) by its respective moment measurement.
2. The EOW is the sum of the measured weight (excluding any leveling blocks).
3. Add the resultant moments to obtain the Empty Weight Momentum (EM).
4. Divide this moment by the EOW to find out the empty weight CG location.

**5.5 - CG location and TOW calculation.**

TOW = EOW + LOAD

To assist you with this calculation, we recommend the use of the second half of the table 1.1.

1. Weigh every item to be included.
2. Multiply the weight of every item added (pilot, passenger, fuel, baggage) by its arm (L3l, L3r, L4 and L5) to obtain the respective moment.
3. The Aircraft Loaded Weight is the sum of the additional weight to the EOW
4. Add the moments of every added item to the EOW moment and divide the result by the weight of the loaded aircraft to find the Position of The CG of the Loaded Aircraft in relation to the datum line.
5. The resultant value must be within the allowable CG range for the aircraft to be Balanced

NOTE: Do not operate the aircraft if the aircraft loaded weight is bigger than the maximum take off weight (MTOW=1,320 lbs), or the CG is outside of the limits (10.93" to 20.12").

The datum is the leading edge of the wings close to the root.

- 1) The distance from the nose gear to the Datum is -25.98" (-660 mm).
- 2) The distance from the main gear to the Datum is +20.47" (+550 mm).

Figure 4 - Datum Line, Arm and CG location.



Paradise P - I LSA

Datum Line, Arm and CG Location

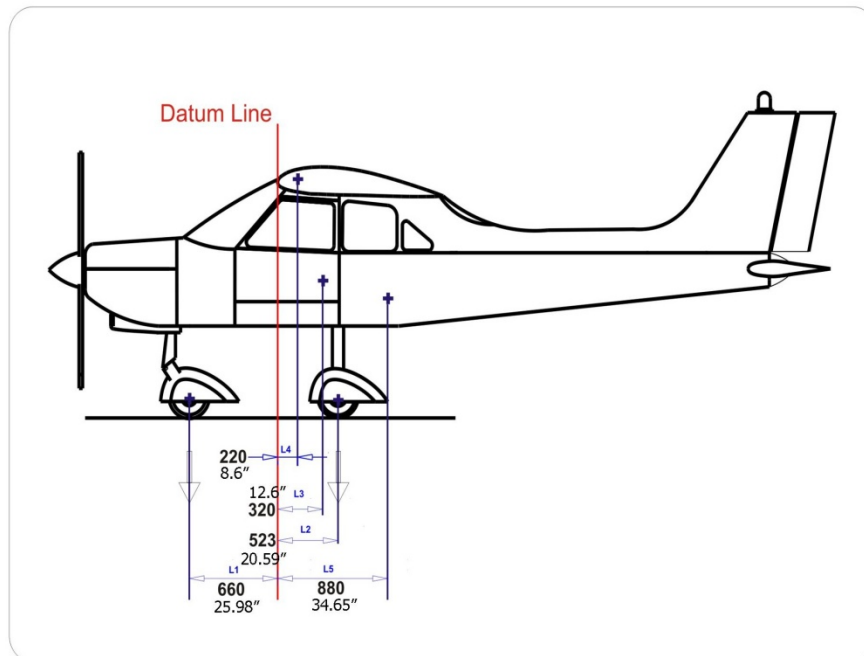



Table 1

Weight and Balance Calculation sheet

		Weight	Arm	Momentum
		(lbs)	(in)	lb.in
Nose wheel	L1			
Left main wheel	L2l			
Right main wheel	L2r			
AIRCRAFT EMPTY WEIGHT	result	EOW=		EM=
Left seat	L3l			
Right seat	L3r			
Fuel tank	L4			
Baggage compartment	L5			
LOAD	result	LOAD=		LM=
LOADED AIRCRAFT	formula	TOW=EOW+LOAD	c.g. =TOW/Tm	Tm=Em+Lm
	found			
DESIGN LIMIT		1,320		



Page intentionally left blank.



6.0 – Performance for P-1 SLSA SW model.

Performance data is based on 1,320 lbs gross weight, sea level and standard atmospheric conditions, unless otherwise noted.

6.1 – Take off and landing distance:

Take off: 460 ft. (140 m).*

Take-off over 50 ft (15 m) obstacle: 726 FT (220 m)*

Landing over 50 ft (15 m) obstacle: 490 FT (150 m)

*NOTE: DISTANCES USING FLAPS SET AT 16°.

6.2 – Best rate of climb:

V_y = 61 Kt (112 km/h).

6.3 – Best angle of climb:

V_x = 52 Kt (96 km/h).

6.4 – Cruise speed:

Cruise speed at 5200 rpm = 110 Kt (202 km/h)

6.5 – RPM

Minimum idle	1400
Static	4700
Normal climb	4800
Maximum	5800 (5 min)
Max. continuous	5500
Normal cruise	4200 - 5200
Cruise @ 75%	5000

6.6 Fuel consumption (gallons and liters per hour).

Climb power	5.12 gal.	(19 l)
Normal cruise	3.44 - 5.82 gal.	(13 - 22 l)
Max cruise	6.88 gal.	(26 l)

7.0 - Emergency procedures

7.1 - ENGINE FAILURE

7.1.1 - If still in the take off run, and there is enough runway to stop.

1. Apply brakes.
2. Idle throttle.
3. Remove flaps.
4. Turn ignition off.
5. Master off.

7.1.2 - If engine fails right after take off.

1. Lower the nose to establish best glide speed of 60 Kts (111 km/h)

NOTE

Unless you are at a safe altitude to return, it is often better to attempt a landing straight ahead.

2. Locate a suitable landing field considering wind direction, slope, obstacles and available unobstructed length. Keep speed as directed to avoid stalling the aircraft.
3. Throttle - idle.
4. Fuel valves (both) closed.
5. Flaps - 36° - Position 4.
6. Magnetos - off
7. Master switch - off
8. Touch down with tail slightly lowered.

NOTE

Keep airspeed as directed, making gentle turns to divert from obstacles, and avoid stalling aircraft.

7.1.3 - If engine fails during flight, to attempt a restart.

1. Lower the nose to establish best glide speed of 61 kts (112 km/h).
2. Throttle - idle.
3. Fuel valves (both) open.
4. Ignition - magnetos (both) - on.
5. Master switch - on
6. Engage starter.
7. After engine starts - accelerate slowly.
(if engine doesn't start proceed as follows)

7.2 - EMERGENCY LANDING**STANDARD EMERGENCY PROCEDURE FOR ALL EMERGENCY LANDINGS**

1. Safety belts - connected and adjusted
2. Speed. See below recommended speed for different situations.
3. Radio - May Day call on 121.5 - inform location and intentions.
4. Transponder - 7700
5. Choose best location available for emergency landing.
6. Evaluate ground conditions for possible standard landing.
7. Identify obstacles such as power lines, poles, fences, rocks, etc.
8. Identify wind direction - **WHENEVER POSSIBLE LAND AGAINST THE WIND.**
9. Heavy objects - if possible dispose of, otherwise make sure they are restrained in luggage compartment.
10. For landing in water make sure no equipment will hinder occupants after landing (special attention to headphones and cables).
11. If severe impact is expected protect face with folded jacket or pillow.
12. Next, specific procedures for different landing conditions.

7.2.1 - EMERGENCY LANDING WITHOUT ENGINE.

1. Speed - establish best glide speed - 61 kts (112 km/h).
2. Throttle - Idle.
3. Fuel valves (both) - off.
4. Ignition - both magnetos off.
5. Flaps as requires (recommended maximum - Position 4)
6. Master - off
7. Choose the best available site for landing.
8. Identify wind direction - **LAND AGAINST THE WIND.**

9. Door locks - unlocked before landing.
10. Touch down - tails slightly lowered.
11. Brakes - apply heavy.
12. Leave aircraft.

7.2.2 - EMERGENCY LANDING WITH ENGINE RUNNING.

1. Speed - establish best glide speed - 61 Kt (112 km/h)
2. Flaps - position 1 - 7°.
3. Landing site - choose best available for standard landing.
4. Once chosen, fly over and observe obstructions and topography.
5. Observe wind direction - LAND AGAINST WIND.
6. Electrical switches - ALL OFF EXCEPT IGNITION.
7. Indicated airspeed - MAINTAIN 56 Kt. (104 km/h)
8. Flaps - position 2 - 16°
9. Reduce speed to 44 Kt. (81 km/h)
10. Flaps - apply to position 4 - 38°
11. Avionics and radios - OFF.
12. Door locks - UNLOCK BEFORE LANDING.
13. Master switch - OFF.
14. Touch down - TAIL SLIGHTLY LOWERED.
15. Touch down speed - 35 Kt. (65 km/h).
16. Ignition (magnetos) - BOTH OFF.
17. Brakes - APPLY HEAVY.
18. Aircraft - POSITION CORRECTLY, TIE DOWN, INSTALL COVERS.

7.2.3 - EMERGENCY LANDING IN WATER

1. Life jackets - ON.

NOTE - DO NOT INFLATE JACKETS INSIDE AIRCRAFT.

3. Safety belts - ENGAGED AND ADJUSTED.
4. Reduce speed to 48 Kt (88 km/h).
5. Flaps - POSITION 2 - 16°.
6. Approach:
 - a. With light winds, low waves - PARALLEL TO WAVES.
 - b. Strong winds, high waves - AGAINST WIND.

NOTE - UNDER NO ENGINE CONDITION - APPROACH SPEED SHOULD BE 44 Kt (81 KM/H) WITH FLAP IN POSITION 2 - 16°.

7. Flap - APPLY GRADUALLY TO POSITION 4 - 38°.
8. Door locks - UNLATCHED.
9. Before touchdown - LEVEL FLIGHT, TAIL SLIGHTLY DOWN.
10. Face - FACE PROTECTED W/PILLOR or FOLDED JACKET.
11. Touch down - LET TAIL TOUCH AND DRAG IN THE WATER BEFORE MAIN WHEELS.
12. Safety belts - REMOVE IMMEDIATELY.
13. Evacuate thru doors - IF NECESSARY OPEN WINDOW VENTILATION TO FLOOD INSIDE AND EQUALIZE PRESSURE TO OPEN DOORS.
14. INFLATE FLOATING DEVICES.

7.3 - ENGINE FIRE

7.3.1 - ENGINE FIRE DURING START UP

A) If engine starts:

1. When engaging starter, continue until engine reaches 2500 rpm. Keep it running at this rpm to "suck in" the flames and the fuel accumulated at the carburetors and engine's admission.
2. Engine RPM 2500 for 2 to 3 minutes.
3. Shut off engine.

B) If engine doesn't start:

1. Throttle - FULL OPEN.
2. Fuel valve - CLOSED.
3. Starter - CONTINUE ENGAGED.
4. Engine - STOP
5. Master - OFF
6. Ignition - magnetos - BOTH OFF.
7. Fire - Use fire extinguisher or sand to stop fire.

7.3.2 - ENGINE FIRE DURING TAKE OFF

A) Is still on take off run and there is enough runway to stop.

1. Brakes - APPLY HEAVY.
2. Throttle - IDLE.
3. Flaps - RETRACT.



4. Ignition - BOTH MAGNETOS OFF.
5. Master - OFF.
6. Fuel valve - CLOSED.
7. Exit aircraft and use fire extinguisher.

B) If on take off run and there is no runway left for a safe stop.

1. Throttle - FULL.
2. Flaps - POSITION 2 - 16°.
3. Speed - Vy - 61 kts (112 Km/h).
4. Altitude - SAFE FOR TRAFIC.
5. Traffic control - NOTIFY AND STATE YOUR INTENTION TO RETURN.
6. Safety belts - APPLIED AND ADJUSTED.



8.0 - Normal Procedures (Flight training supplement)

8.1 - Preflight check

8.1.1 - Approaching Aircraft

1. Remove any tie downs, external control locks, wheel chocks and pitot cover.
2. Look for any signs of fuel or oil spillage.
3. Check ground level (a sloping ground can affect visual gas check).

8.1.2 - Inside cabin

1. Remove locks and covers and stow properly.
2. Magneto switch should be on **OFF** position and key out.
3. Test parking brake by pushing on wing strut.
4. Turn Master Switch ON, landing lights, navigation and beacon ON, walk around and check visually for proper operation. - Anti collision beacon. Navigation lights colors are: Left side (pilot) - RED - Right side (co-pilot) GREEN. Tail WHITE.
5. Fuel shut off valve: Check position for both OPEN. Check quantity gauges.
6. Check flap area for clearance - lower to full position (38°)
7. Turn master switch **OFF**.
8. Check fire extinguisher for security and gauge should be on green.

8.2 - External Inspections: Begin and end your check at the rear of the wing.

8.2.1- Left landing gear (Pilot side)

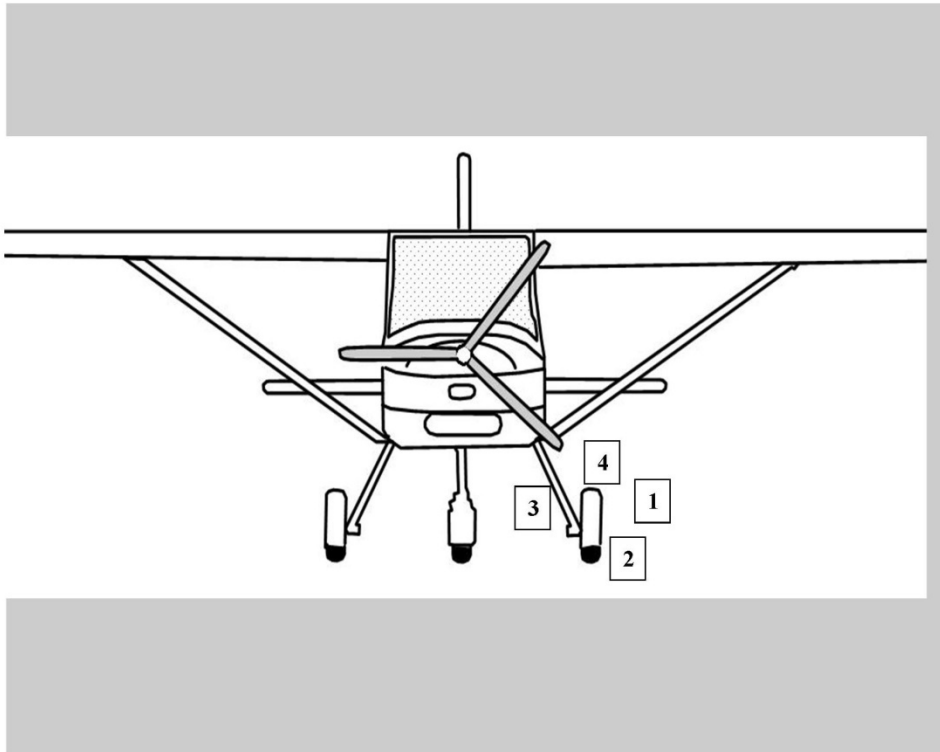

1. Tire - Check the tread for wear and cuts, general condition and inflation.
2. Hydraulic lines - Inspect for leakage - (red fluid).
3. Disc brake should be shiny and not rusty or pitted.
4. Fairing - Check for proper installation and damage by mud or rocks.

8.2.2 - Left Wing (pilot side)

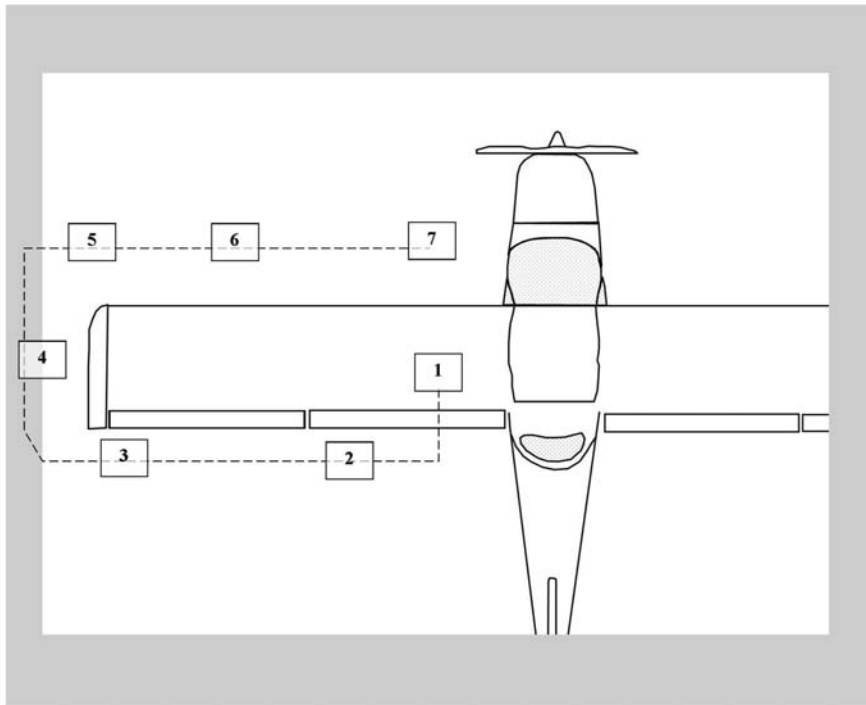

1. Inspect strut and fairings.
2. Flap - Inspect both lower and upper surface for damage. Check linkage for security and grease. Test flap for pin wear on different extension levels.
3. Aileron - Check upper and lower surfaces, check for hinge wear, lubrication, and free movement (*do not force*).
4. Wing tip check for proper installation, inspect navigation lights for damage.
5. Check lower wing surface for damage and loose rivets.
6. Inspect wings leading edge for damage. Test stall horn (you may use your mouth to produce a suction force but place a cloth over hole to avoid bugs and dirt), inspect pitot tube's orifice for blockage.
7. Inspect fuel quantity visually. Secure cap after inspection. Drain at least 3 oz from each tank drain. Check for correct color, water bubbles or sediment. Make sure the drain is not leaking.

8.2.3 - Front Fuselage and Engine

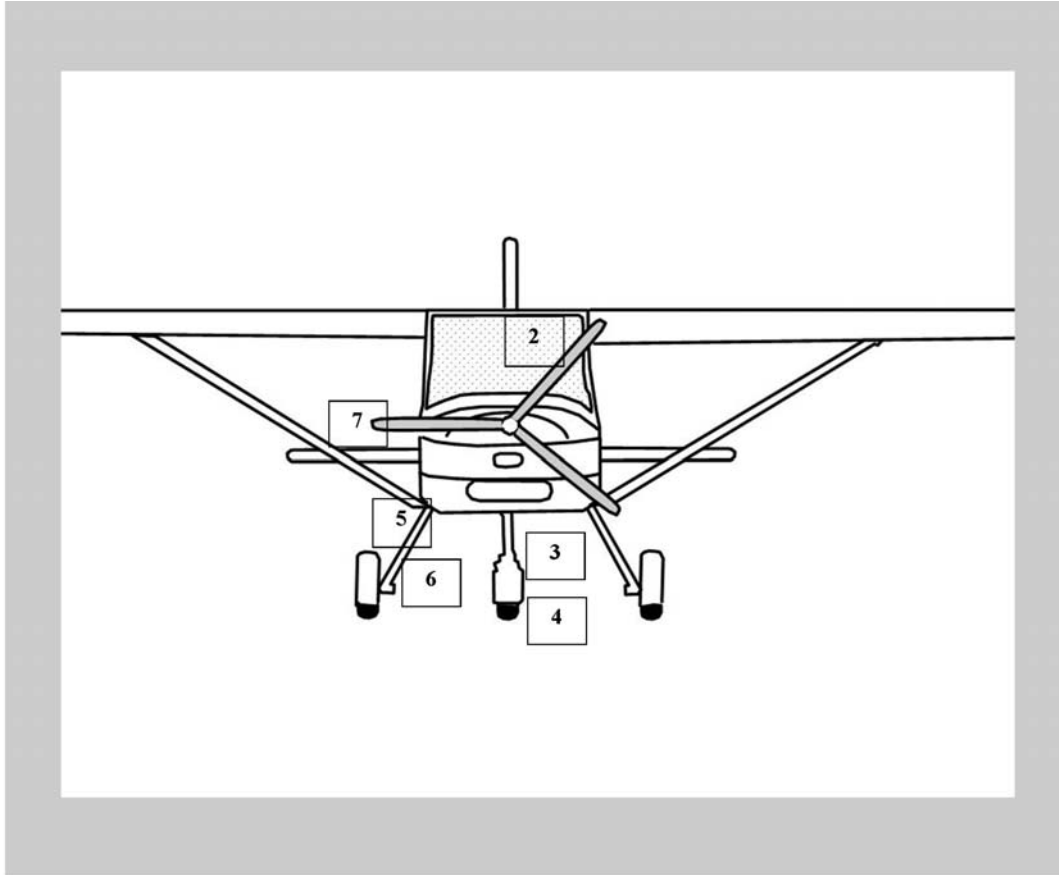

1. Check cowling on left side for security and conditions. Check static port (*do not blow into port*).
2. Windshield should be clean. Check for cracking.
3. Check nose strut for proper linkage, pin, nut and security.
4. Check nose wheel for proper inflation and tire wear.
5. Check front of cowling for security, damage, clear intakes and landing light undamaged.
6. Check propeller for cracks or chips. Check if spinner is secure and in good condition.
7. Open access door on right side of cowling, check oil level. (Do not over tight dipstick when installing). Inspect coolant level. Inspect visually engine compartment and assure that access door is properly closed. Cowling should be secure and in good condition.

8.2.4 - Right Wing (co-pilot)

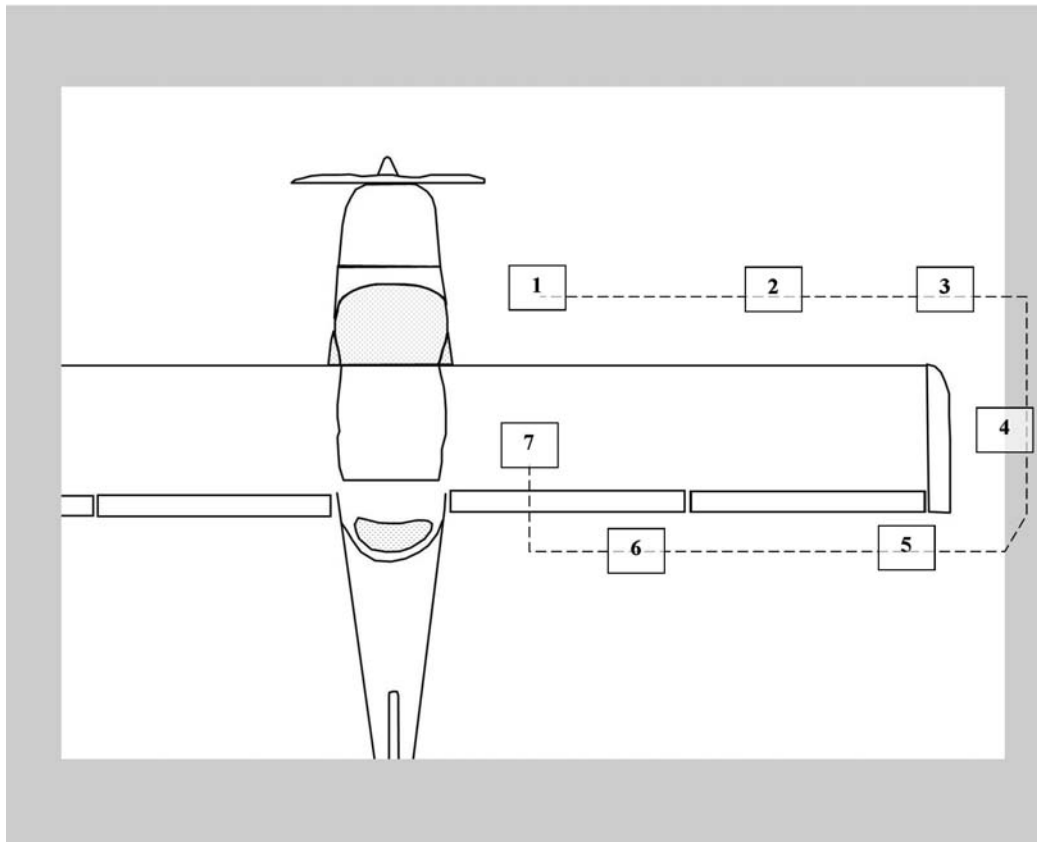

1. Inspect fuel quantity visually. Secure cap after inspection. Drain at least 3 oz from each tank drain. Check for correct color, water bubbles or sediment. Make sure the drain is not leaking.
2. Inspect wings leading edge for damage.
3. Check lower wing surface for damage and loose rivets.
4. Wing tip check for proper installation, inspect navigation lights for damage.
5. Aileron - Check upper and lower surfaces, check for hinge wear, lubrication, and free movement (*do not force*).
6. Flap - Inspect both lower and upper surface for damage. Check linkage for security and grease. Test flap for pin wear on different extension levels.
7. Inspect strut and fairings.

8.2.5 - Right Side Landing Gear (co-pilot)

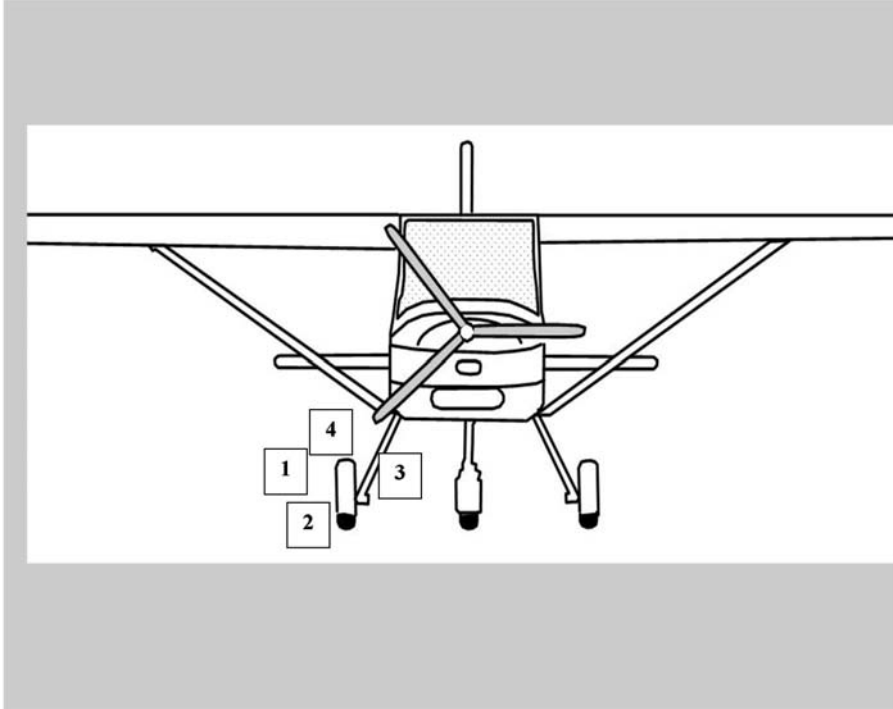

1. Tire - Check the tread for wear and cuts, general condition and inflation.
2. Hydraulic lines - Inspect for leakage - (red fluid).
3. Disc brake should be shiny and not rusty or pitted.
4. Fairing - Check for proper installation and damage by mud or rocks.

8.2.6 - Right Side Fuselage

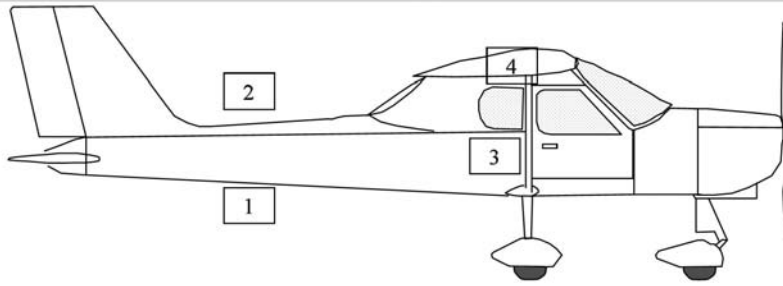

1. Inspect skin for general surface condition. *Cracks, dents and rivets.*
2. Inspect radio, transponder and ELT antennas.
3. Check latch and hinges of door.
4. Check windows for cracks, damage and clean.

8.2.7 - Tail Section

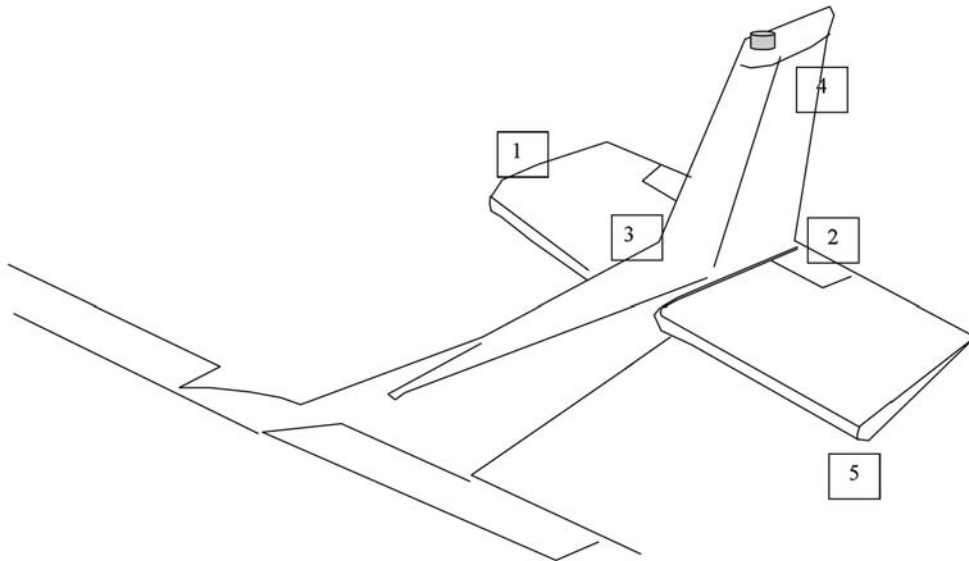

1. Elevator - right and left side - check lower and upper surface for condition. Linkage and free movement (*do not use force*).
2. Trim Tab - Check linkage, condition and correct movement in relation to elevator.
3. Check condition of tail fin, antennas and rotating beacon.
4. Rudder - check condition, linkage, hinges and free movement (*do not use force*).
5. Check under tail surface for condition of protection rod and tail tie down hook.

8.2.8 - Left Side Fuselage

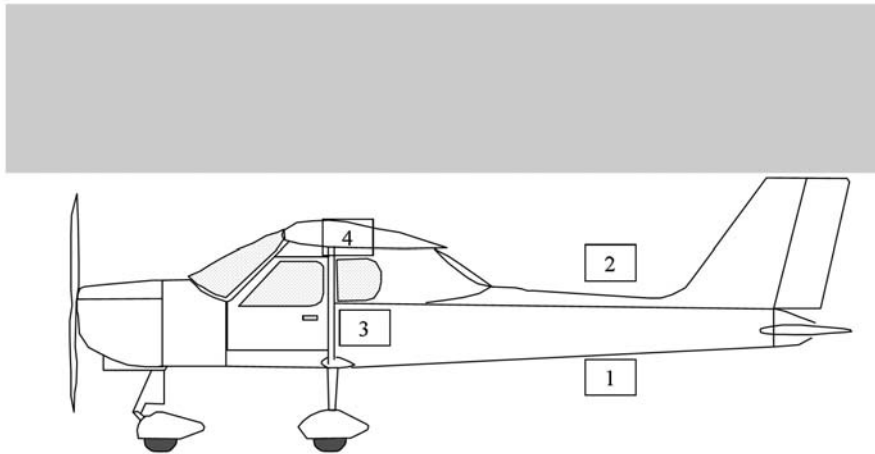

1. Inspect skin for general surface condition. Cracks, dents and rivets.
2. Check dorsal fin for condition. Cracks, dents and rivets.
3. Check door latch and hinges.
4. Check windows for cracks, damage and clean.



8.3 - Engine starting:

- | | |
|-------------------------------|-------------------|
| 1. Preflight | COMPLETE |
| 2. Parking brake | SET (up position) |
| 3. Carburetor heat | OFF |
| 4. Circuit breakers | IN |
| 5. Radio/electrical equipment | OFF |
| 6. Master switch | ON |
| 7. Anti collision lights | ON |
| 8. Fuel valve | BOTH |
| 9. Ignition key | IN |
| 10. Choke | AS REQUIRED |
| 11. Throttle | CLOSED |
| | " CLEAR PROP" |
| 12. Starter | ENGAGE |
| 13. Choke | RELEASE |
| 14. Oil Pressure | CHECK |
| 15. Radios | ON |

8.4 - Taxiing:

Speed control is important, especially when taxiing over rough surface or strong wind conditions. Aileron and stabilator should be kept in a manner to reduce or neutralize wind effect.

- | | |
|------------------------------|----------------|
| 1. Seat belts | ON & ADJUSTED. |
| 2. Landing lights | ON |
| 3. Break system and steering | CHECK |

STEER WITH LOWER PART OF PEDALS - APPLY BRAKES ONLY AS NEEDED.

8.5 - Run Up

POSITION AIRCRAFT FACING THE WIND

- | | |
|------------------|--------------------|
| 1. Parking brake | SET. (up position) |
| 2. Seat belts | ON & ADJUSTED. |
| 3. Doors | CLOSED. |
| 4. Controls | TEST |



- 5. Instruments ADJUST
- 6. Choke OFF
- 7. Throttle 3200 rpm
- 8. Magnetos
CHECK LEFT, RIGHT & BOTH - rpm drop shouldn't exceed 300 and maximum difference 120 rpm.
- 9. Oil temperature Minimum 124°F (51° C).
- 10. Throttle IDLE.
- 11. Flaps ADJUST as NEEDED.
- 12. Trim SET.
- 13. Radios SET.
- 14. Parking brake RELEASE. (lower position)

8.6 - Normal takeoff:

- 1. Flaps 16°.
- 2. Throttle FULL.
- 3. Rotate 48 Kts.

8.7 - Best angle of climb speed (VX): 52 Kts (85 km/h).

NOTE: Best angle of climb speed: Vx = 52 Kts, Flap16°

8.8 - Best rate of climb speed (VY): 61 Kts (112 km/h).

NOTE: Best rate of climb speed: Vy = 61 Kts, Flap 16°

8.9 - Cruise: 101 Kts. (187 km/h).

NOTE: Cruise at: 75% = 5,000 rpm.

8.10 - Approach: 49 Kts (90 km/h).

NOTE: Speed for 16° of flaps (2 notches).

8.11 - Landing: 39 Kts (72 km/h).

**8.12 - Short field takeoff:**

1. Flaps 16°.
2. Brakes APPLY AND HOLD.
3. Throttle FULL.
4. Brakes RELEASE.
5. Rotate 44 kts (81 km/h).

8.13 - Short field landing:

1. Flaps FULL
2. Throttle AS NEEDED.
3. Approach speed 44 kts (80 km/h).
4. Touch down speed 39 kts (72 km/h).
5. After touch down THROTTLE IDLE.
6. Brakes APPLY STRONG.
7. Flaps FULLY RETRACTED.

NOTE: MAKE SURE PARKING BRAKE HANDLE IS ON OFF (down) POSITION .Touch down on main wheel only, keep nose wheel in the air as long as possible.

8.14 - Go around (Balked landing) procedures:

1. Throttle FULL.
2. Flaps 16°.
3. Airspeed 44 kts (81 km/h)



9.0 - STALLS, SPINS AND OTHER USEFUL INFORMATION:

NOTE: THE INFORMATION ON THIS SECTION IS NO SUBSTITUTE FOR PROPER FLIGHT TRAINING UNDER THE GUIDANCE OF A FLIGHT INSTRUCTOR FAMILIAR WITH THE AIRCRAFT AND ITS CHARACTERISTICS.

Stalls

The Paradise P-I has the conventional stall characteristics with some stabilator buffeting before the stall. There is no roll tendency when entering a coordinated stall. Directional control should be maintained by use of the rudder.

Recovery should be accomplished by pushing in the yoke to reduce the angle of attack and gain airspeed. Typical height loss is around 100 ft. for a full stall with conventional power use recovery.

Spins

The Paradise P-I is not certified for spins.

In an event on an unintentional spin you should:

1. Reduce power to idle.
2. Neutralize ailerons.
3. Apply full rudder in the opposite rotation direction.
4. Once rotation stops, smoothly recover from the dive.

Steep turns

Enter turns with coordinated rudder/ailerons and increase power and pitch as necessary to maintain airspeed and altitude. Do not exceed 60° of angle.

10.0 - GROUND HANDLING and SERVICING.

10.1 - Fuel, oil and coolant.

10.1.1. - Fuel

Proper ground must be established before fueling.

The fuel tanks are equipped with safety caps located at the upper wing surface. Caps must be in place and locked before flight. You may check the fuel quantity in the tanks by means of the calibrated dipstick supplied with the aircraft.

10.1.2 - Oil

To measure oil level:

1. Open engine inspection window on upper cowling.
2. Twist the oil tank cap, and check level on dipstick.
3. Set parking brakes.
4. Check that master switch is off, key out of ignition, and both magnetos off.
5. Turn the propeller in the direction of rotation until air is bled from system. ("gurgle" sound).
6. Check oil level on dipstick.
7. Add as needed to keep level between min and max marks on stick, and replace cap using hand pressure to secure properly.

10.1.3 - Coolant

To check level:

1. Set parking brakes.
2. Check that master switch is off, key out of ignition, and both magnetos off.
3. Remove top cowling.
4. Open coolant cap and fill as needed.
5. Make sure there is no air inside the cooling system.
6. Close coolant tank cap.
7. If needed, add coolant to expansion bottle.

10.2 - Towing

NOTE: The Paradise P-I can be moved by one person, using the tow bar. If needed, you may turn aircraft around by pushing down on the tail boom to lift the nose wheel off the ground.

1. Make sure parking brake is off.
2. Remove tie downs from wings and tail.
3. Check that the area around the aircraft is clear of obstacles and people.
4. Install tow bar on nose wheel attachment.
5. Push or pull aircraft in the needed direction.

10.3 - Tie down

1. Install wheel shocks.
2. Apply parking brakes. (down position)
3. Check all lights, avionics, transponder, gps and radios are off.
4. Close window vents.
5. Check that flaps are retracted.
6. Tie down yokes using seat belt.
7. Do a 360° inspection, checking wings, fuselage, landing gear and prop.
8. Install tie down lines on each wing hook located on underside of the wings.
9. Install tie down line to hook under the tail section.
10. Install pitot cover.
11. Install windshield cover.
12. Lock both doors.

10.4 - Required Placards and Markings.

10.4.1 - Airspeed indicator range markings

White range (flap operating range) - 41 to 70 kts	(76 to 130 km/h).
Green range (normal operating range) - 49 to 105 kts	(56 to 194 km/h).
Yellow range (caution range) - 105 to 121 kts	(194 to 224 km/h).
Red line (never exceed speed) - 121 kts	(224 km/h).

10.4.2 - Instrument panel operating limitations

1. Max RPM - 5,800.
2. Max EGT - 1,616° F - 880° C.
3. Max CHT - 248° F - 120° C.
4. Max Oil temp - 266° F - 130° C.
5. Oil pressure - 102 PSI - 7 Bar.

10.4.3 - Passenger Warning

The warning "This aircraft was manufactured in accordance with Light Sport Aircraft airworthiness standards and does not conform to standard category airworthiness requirements" is placed on the instrument panel where the passenger can see it.



10.4.4 - "NO INTENTIONAL SPINS".

The placard "NO INTENTIONAL SPINS" is placed close to the airspeed indicator.

10.5 - Miscellaneous placards and markings.

Speeds and limitations, placed at the panel right hand side.

<p><u>P1 LSA SW Speeds and Limitations</u></p> <p>Stall clean: 44 knots. Stall 16° = 40 knots.</p> <p>Maneuvering Speed $V_A = 95$ Kt Never Exceed Speed $V_{NE} = 125$ Kt</p> <p>Best rate of climb - $V_Y = 60$ Kt Best angle of climb - $V_x = 52$ Kt Best glide speed = 60 Kt</p> <p>Max T/Off Flaps - 2 notches = 16°</p> <p>Normal landing Flaps = 16° Approach = 50 Kt Touch down = 45 Kt</p> <hr/> <p>Max CHT - 275° F Oil Temperature - 120-266° F</p>
--

Fuel type and quantity: one near each fuel cap on upper wing.

<p>FUEL</p> <p>MINIMUM 91 Octane auto fuel or 100 LL Av Gas</p> <p>13.1 gallons per side (12.5 usable)</p>

<p>PARKING BRAKES OFF BEFORE LANDING</p>
--



Tachometer 5800 rpm.

Oil pressure gauge max 102 psi (7 bar).
Min 12 psi (0, 8 bar).

Oil temperature gauge 266° F (130°C).

Water temperature gauge 248°F (120°C).

Ignition

AC OFF ON START

Magnetos

Mag A Mag B

Gas valve

LEFT TANK RIGHT TANK BOTH OPEN BOTH CLOSED

Choke

PULL to CHOKE

Oil

Oil Pressure

Oil temperature

CHT

CHT - Left side

CHT - Right side

Breakers/Switches

Transp Radio Strobe Nav GPS L.Lights Panel Instr

Rudder trim



Throttle



Parking brake





Baggage compartment

Baggage Compartment

**Maximum
77 lbs. (35 kg)**



NOTE

To "drive" an aircraft is not such a complex activity. To pilot an aircraft is an art. To be a pilot is more than be able get the plane of the ground and back with reasonable safety. To be a pilot is:

- Be technically and physically able for the activity;
- Have ability, experience and master the art of flight;
- Know the aircraft, its limits, performances and operational systems;
- Have solid a knowledge of weather and navigation;
- Be permanently trained to face abnormal and emergency situations;
- Be prudent and responsible;
- Be humble and know your own deficiencies.

Constant training to face abnormal and emergency situations, reading technical material and the exchange of experiences and ideas with more experienced pilots are very important for the formation of a good pilot.

Finally Remember:

Excess speed can cause structural damage to aircraft
Lack of speed can lead to stall and spins
Safety is up in the air not close to the ground.



Page intentionally left blank.



Paradise - Model. P-I - LSA Standard Version.

Manufactured and sold by:

Paradise Industria Aeronautica Ltda.
Rod. Ba 001, Km 13,5
Bairro Conceicao
Vera Cruz, Bahia, Brazil

Phone: 55-71-3681.7481

Fax: 55-71-3681.7720

WWW.Paradise-Ultraleve.com

e-mail: PRDSE@terra.com.br

US representative:

Paradise USA LLC
446 Hendricks Field Way
Sebring, Fl 33870

Phone: 561 632 8428

Fax: 561 686 7999

WWW.ParadiseAircraft.us

E-mail: PRO@ParadiseAircraft.US

For assistance: Assistance@Paradise-ultraleve.com

To report problems: Airworthiness@Paradise-ultraleve.com



APPENDIX A

LIST OF INSTALLED EQUIPMENT

STANDARD P-1 SLSA AIRCRAFT

EQUIPMENT

1. Adjustable seats (length), back angle.
2. Shoulder and hips safety belts.
3. Luggage compartment behind the seats.
4. Carpeted luggage area.
5. Safety cargo hooks.
6. Leather covered seats, with head rest.
7. Insulated cabin and baggage area for heat and sound.
8. Cabin heat.
9. Map compartment behind seats.
10. Panoramic doors with map compartment.
11. Rear and quarter windows.
12. Double yoke with PTT.
13. Double hydraulic brake.
14. Toe brakes.
15. Steering rubber dampened nose wheel.
16. Throttle control lever on front console.
17. Throttle lever friction lock wheel. (On right side of console).
18. Manual elevator trim on floor (between seats).
19. Manual operated flap lever (between seats).
20. Rudder trim control wheel (on console).
21. Parking break control (on left side door post).
22. Combination key switch.
23. Left/Right/Both/Closed wing fuel tank control valve.
24. Two independent wing tanks (12.5 gal useful each).
25. Left and right magneto switches w/protector cover.
26. Large inspection cowling window.
27. Quick fasteners cowling.
28. Wheel fairings.
29. Landing lights.
30. Navigation lights.
31. Strobe light.



NOTE: "Not equipped with carburetor heat."

FLIGHT INSTRUMENTS

1. Airspeed indicator - 20-160 MPH -
2. Vertical speed indicator. - 2.000 FPM.
3. Three pointer altimeter w/barometric window. - 20,000 ft. - Inches.
4. Magnetic compass - Northern Hemisphere.
5. Inclinator.

ENGINE

1. Rotax 912 ULS 2 (100 hp).
2. Tachometer.
3. Oil pressure.
4. Oil temperature.
5. CHT left bank.
6. CHT right bank.
7. Voltmeter.
8. Hour meter.
9. Choke.

PROPELLER

1. Warp Drive 3 bladed ground adjustable propeller.
2. Nickel edge protector.
3. Spinner.

OTHER

1. Radio.
2. Transponder w/ "C" mode.
3. Headphone jacks.

OPTIONAL

1. GPS.
2. Artificial horizon.
3. Glass panel.
4. Auto pilot.
5. Stereo intercom.
6. Night VFR package.



Page intentionally left blank.



APPENDIX B

ROTAX OPERATOR'S MANUAL

To print a free copy of the operator's, maintenance and other engine manuals, go to:

<http://www.kodiakbs.com/tiintro.htm>